

Thin Cutting Frame Saw MAMUTH Plus

The Thin Cutting Frame Saw **Mamuth** was developed for cutting solid wood blocks into glueable veneers with a minimum of saw kerf waste. The machine is provided by standard accessories listed below. The Mamuth is a very heavy duty version of thin cutting frame saw for lumbers up to 220 mm wide and up to 350 mm high.

Mamuth Plus



Features

- Play-Free Linear Guides for Smooth Carriage movement.
- Easy Access for Saw Frame Changing
- Automatic Central Lubrication System
- Precision Start/Stop Feed System
- Cutting height up to 350 mm
- Adjustable Chip Breaker
- Solid Steel Crank Arms

Standard Equipment

- *Automatic Raise/Lower of Top Feed Rollers via Push button*
- *Driven Top and Bottom Feed Rollers*
- *Dust Free Enclosed Gear Boxes*
- *Side or Center Guide System*
- *Cast Iron Carriage*
- *Air Blast System*

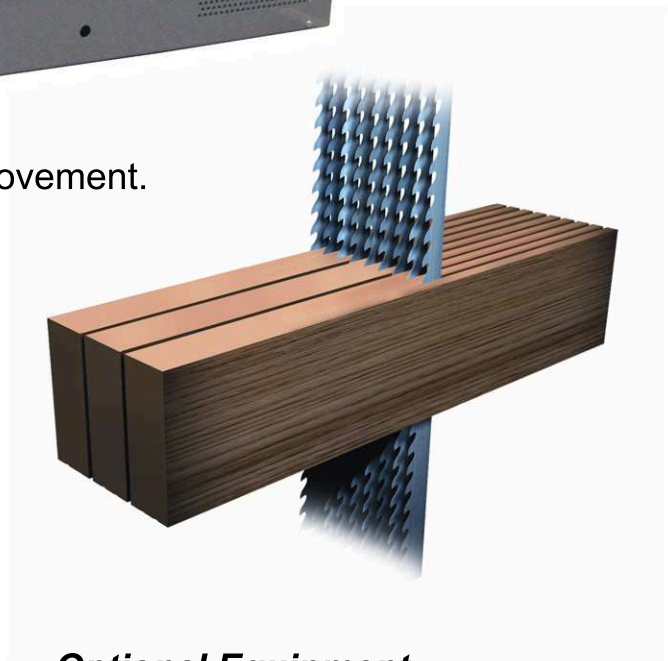

Optional Equipment

- *Wet/Green Lumber Cutting Option*
- *Channel Guide System*
- *Top/Bottom Planer*
- *Hopper Feed*

WORLD LEADER

SINCE 1793

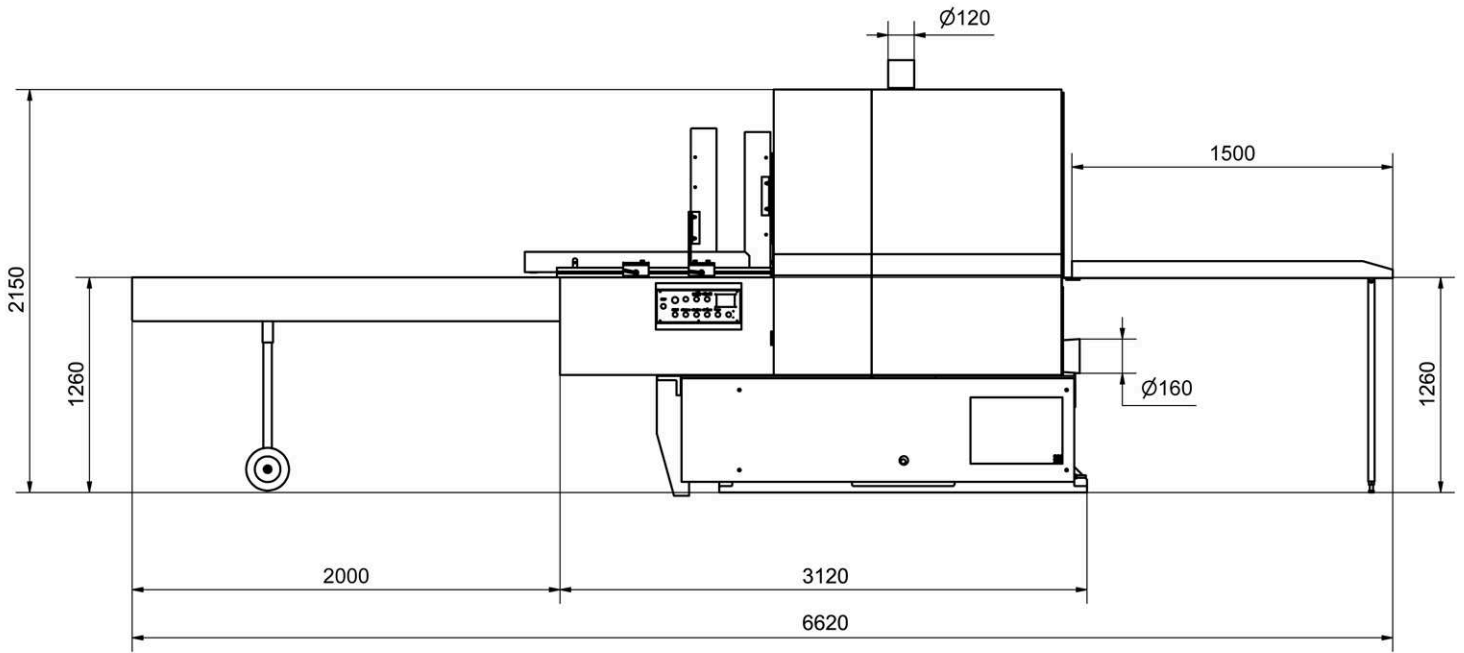

Production capacity	
Slat production per shift (m ²)	650 – 1000
Feed Speed (m/min.)	0.2 – 2.0
Motors	
Main Motor (kW)	22
Motor to open machine (kW)	0.18
“Plus” System Motors (kW)	0.18 (2x)
Machine Dimensions	
Length (mm)	3300
Width (mm)	1000
Height max. (mm)	2300
Weight (kg)	4500

Technical data	
Frame Saw Stroke Length (mm)	250
Strokes per Minute (rpm)	400
Cutting height (mm)	320 / 350
Cutting width (mm)	220
Kerf (mm)	from 0.9
Min. Slat Thickness (mm)	2.0
Min. Block Length (mm)	250
# of Top/bottom Drive Rollers	12/4
Top Dust Hood (Ø mm)	120
Bottom Dust Hood (Ø mm)	160
Air Speed (m/s)	25
Compressed air – min. (bar)	4.5
Compressed Air Volume (m ³ /h)	2 – 10



NEVA – TRADE s. r. o.

Husova 537
 CZ - 378 21 Kardašova Řečice
 tel: 00420 384 377111
 fax: 00420 384 377187
 e-mail: neva@neva.cz

www.neva.cz

