

NBS 300 for CNC Sharpening of Band Saw Blades

The next generation of CNC sharpening machines, the NBS 300 brings the joy of sharpening process - higher quality sharpening results, operator safety and remote access support via internet - backup programs; software updates; via PC or smart phone access to machine display; remote service support; integration into the production process and gathering technological data, etc.

The machine is ideal for the sharpening of stellite, CV, bimetal and carbide-tipped band saw blades up to 300 mm wide. It operates with ceramic, CBN or diamond grinding wheels using water cooling. Driven diamond dressing wheel with automatic cycle is installed in order to keep the shape of ceramic stone clean and consistent. Thanks to this, the stable and consistent tooth shape of the sharpened blade is ensured.



The NBS 300 is equipped by transverse axis and therefore trapezoidal or alternately slanted teeth can be sharpened. Another advantage of the machine is the servo-controlled feeding finger, which ensures a faster cycle run, since it starts to feed as soon as the grinding wheel moves back.

Alternately slanted teeth sharpening

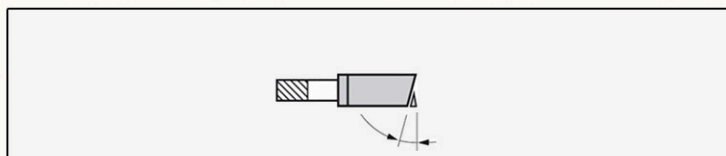

Sharpening of trapezoidal teeth

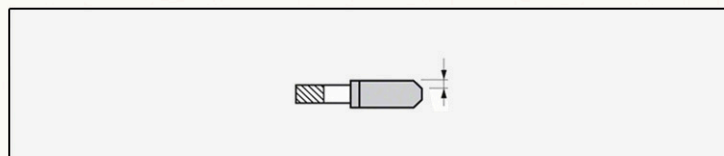

NBS 300 for CNC Sharpening of Band Saw Blades

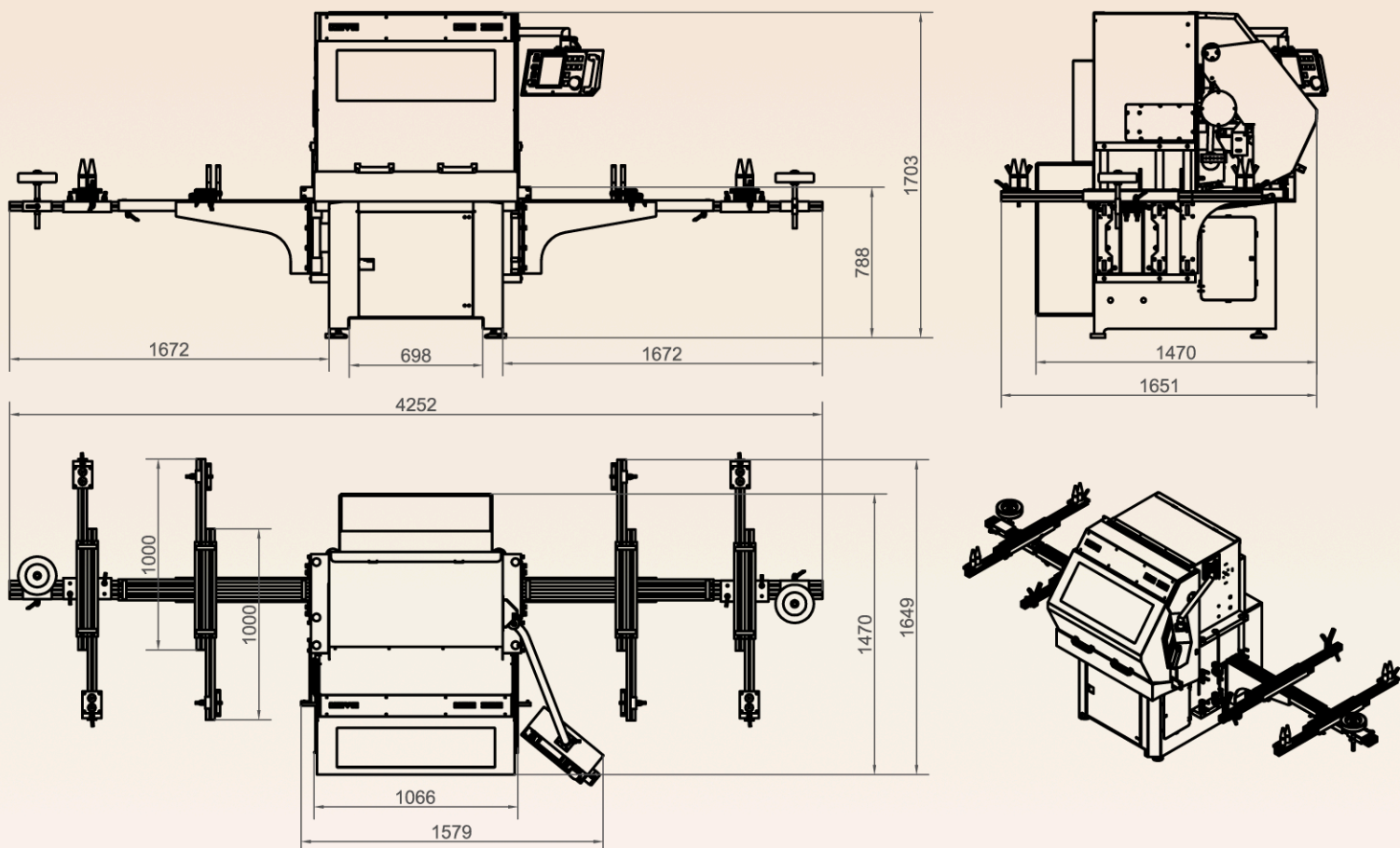

Tooth Designer



Free applications for your NBS machine



Remote Display

Technical specification

Band saw blades length	3500 – 12000 mm
Band saw blades width	80 – 300 mm
Thickness of body	0.5 – 3.0 mm
Tooth pitch	3 – 75 mm
Tooth depth – max.	20 mm
Face angles	0° – 35°
Back tooth angles	0° – 20°
Working speed	100 – 5000 mm/min.
Grinding wheel max. speed via frequency inverter	50 m/s
Grinding wheel diameter	250 mm
Diameter of the shaft of grinding wheel	32 mm
Breadth of the grinding wheel	6 – 10 mm
Compressed air – min.	6 bar
Compressed air volume	approx. 2 m ³ /h

Motor specifications

Spindle motor with frequency inverter	0.55 kW
Servo motor X – vertical axis	0.40 kW
Servo motor Y – transverse axis*	0.40 kW
Servo motor Z – horizontal axis	0.40 kW
Servo motor A – finger	0.40 kW
Pump motor	0.55 kW
Dressing wheel motor*	0.060 kW

Machine dimensions

Width	4250 mm
Depth	1650 mm
Height	1700 mm
Weight	1200 kg