

4. Machine dimensions

The machine has 2 working stations:

- Working station 1 – the control panel and the Infeed of the machine.
- Working station 2 – the machine Outfeed.

The space required on either side of the machine depends on the maximum size of the material.

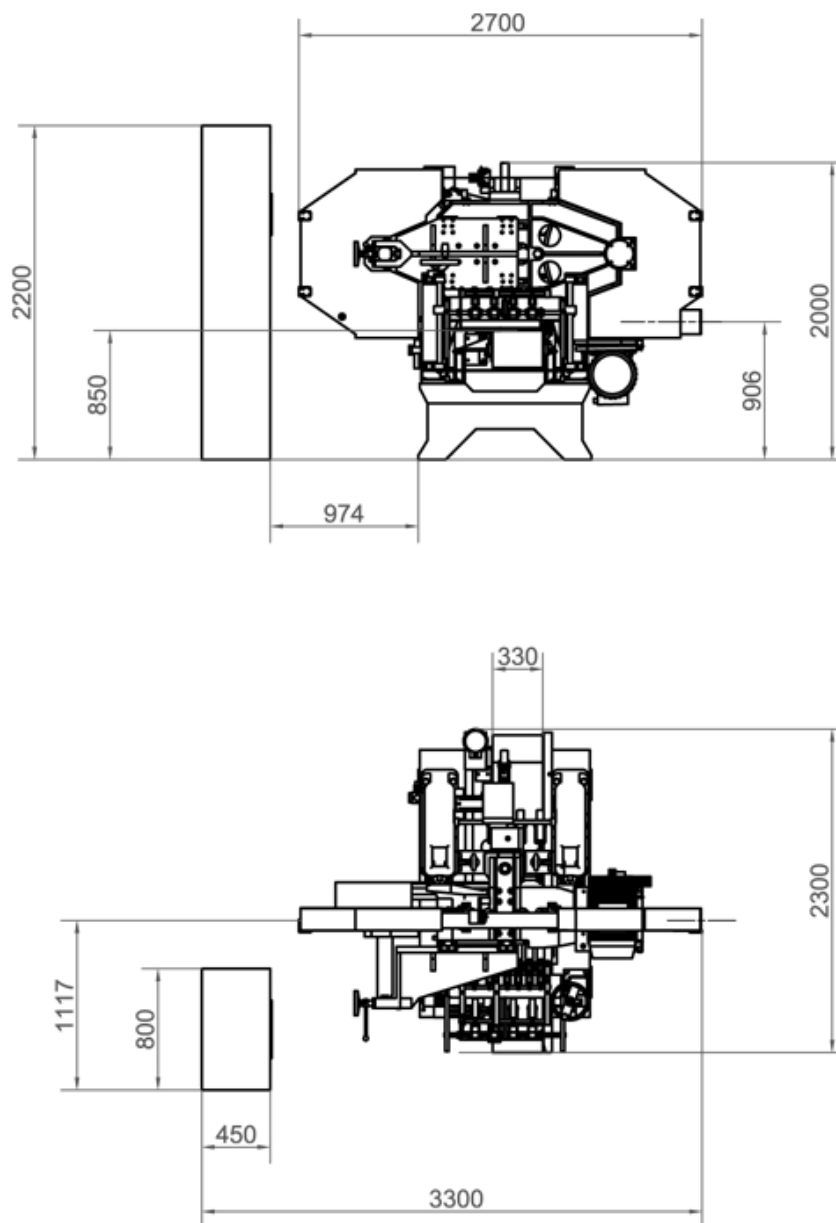

Picture Nr. 2 – Machine dimensions – pravítko vpravo